

Miniature resistance thermometer For sanitary applications Model TR21-A, with flange connection

WIKA data sheet TE 60.26



Applications

- Sanitary applications
- Food industry
- Beverage industry
- Bio and pharmaceutical industry, production of active ingredients

Special features

- Sensor can be calibrated without having to open the process or disconnect the electrical connections
- Compact design for space-saving fitting
- Simple and fast connection using an M12 plug connector
- Output signal: Pt100 or 4 ... 20 mA via PC-programmable transmitter
- Materials and surface finish quality in accordance with standards of hygienic designs



Resistance thermometer model TR21-A with
VARIVENT® connection

Description

The model TR21-A resistance thermometer is used for temperature measurement in sanitary applications. These thermometers are equipped with thermowells, the process connections of which meet the stringent requirements for hygienic measuring points in terms of material and design.

For easy calibration or maintenance, the sensor is removable without having to break into the process or disconnect the electrical connection. Thus hygiene risks can be minimised and downtimes can be reduced.

The spring-loading, integrated into the union nut, guarantees the contact between the sensor tip and the bottom of the thermowell and thus ensures a short response time and lasting high accuracy.

The welded junction between the thermowell and the flange makes the use of a sealing as additional material in those areas redundant which are in contact with the product.

Specifications

Output signal Pt100	
Temperature range	Measuring range -50 ... +150 °C, -50 ... +250 °C
Measuring element	Pt100 (measuring current: 0.1 ... 1.0 mA) standard measuring resistor Pt100 (measuring current: 0.1 ... 1.0 mA) face-sensitive measuring resistor ¹⁾
Connection method	3-wire 4-wire
Tolerance value of the measuring element ²⁾ per DIN EN 60751	Class B Class A Class AA

Output signal 4 ... 20 mA	
Temperature range	Measuring range -50 ... +150 °C, -50 ... +250 °C ³⁾
Measuring element	Pt100 (measuring current: 0.5 mA) standard measuring resistor Pt100 (measuring current: 0.5 mA) face-sensitive measuring resistor ¹⁾
Connection method	3-wire
Sensor tolerance value ^{2) 4)} per DIN EN 60751	Class B Class A Class AA
Measuring span	minimum 20 K, maximum 300 K
Basic configuration	Measuring range 0 ... 150 °C, other measuring ranges are adjustable
Analogue output	4 ... 20 mA, 2-wire
Measuring deviation per DIN EN 60770, 23 °C ±5 K	0.2 % (transmitter) ⁴⁾
Linearisation	linear to temperature per DIN EN 60751
Linearisation error	±0.1 % ⁵⁾
Switch-on delay, electrical	< 10 ms
Signalling of sensor burnout	configurable: NAMUR downscale < 3.6 mA (typically 3 mA) NAMUR upscale > 21.0 mA (typically 23 mA)
Sensor short-circuit	not configurable, generally NAMUR downscale < 3.6 mA (typically 3 mA)
Load RA	$RA \leq (UB - 10 V) / 0.023 A$ with RA in Ω and UB in V
Effect of load	± 0.05 % / 100 Ω
Power supply	DC 10 ... 35 V
Max. permissible residual ripple	10 % at 24 V / maximum 300 Ω Load
Power supply input	protected against reverse polarity
Power supply effect	± 0.025 % / V
Electromagnetic compatibility (EMC)	2004/108/EC, EN 61326 emission (Group 1, Class B) and interference immunity (industrial application) ⁶⁾
Temperature units	configurable °C, °F, K
Info data	TAG No., descriptor and message can be stored in transmitter
Configuration and calibration data	permanently stored in EEPROM
Electrical connection	M12 x 1, 4-pin circular connector

Ambient conditions	
Ambient and storage temperature	-40 ... +85 °C
Case ingress protection	IP 68 ⁷⁾ / IP 69K per IEC 529 / EN 60529 The stated ingress protection only applies when plugged in using mating connectors that have the appropriate ingress protection.
Response time ⁸⁾	t ₅₀ < 4.7 s t ₉₀ < 12.15 s
Materials	Case and union nut: stainless steel 1.4571 (316Ti) Spring: stainless steel 1.4310 Measuring insert: stainless steel 1.4571 (316Ti)

Readings in % refer to the measuring span

For a correct determination of the overall measuring error, both sensor and transmitter measuring deviations have to be considered.

- 1) Face-sensitive measuring resistors, through their small design they serve to reduce the heat dissipation with short insertion lengths.
Available for the temperature range -50 ... +150 °C in classes A and B.
For thermowell insertion lengths of less than 11 mm, face-sensitive measuring resistors are generally used.
- 2) For detailed specifications for Pt100 sensors, see Technical information IN 00.17 at www.wika.com.
- 3) The temperature transmitter should therefore be protected from temperatures over 85 °C
- 4) For measuring spans smaller than 50 K additional 0.1 K
- 5) ± 0.2 % for measuring ranges with a lower limit less than 0 °C
- 6) Use RTDs with shielded cable, and ground the shield on at least one end of the lead, if the lines are longer than 30 m or leave the building.
- 7) 1 MWS/ 24 h
- 8) Measurement in accordance with DIN EN 60751

Thermowell model TW22

Surface finish	Standard: $R_a < 0.8 \mu\text{m}$ Optional: $R_a < 0.8 \mu\text{m}$ electropolished, $R_a < 0.4 \mu\text{m}$, $R_a < 0.4 \mu\text{m}$ electropolished
Materials	Stainless steel 1.4435 (316L)
Connection to the thermometer	G 3/8"
Thermowell diameter	6 mm, optional: probe tip reduced to 4.5 mm (from $U_1 > 25 \text{ mm}$)
Insertion length U_1 ⁸⁾	Standard: 25, 50, 75, 100, 150, 200 mm other insertion lengths are available as options
Pressure ratings	cf. table of dimensions

8) For the TR21-A design without thermowell, the insertion length is defined by the dimension A (see Dimensions in mm).
The thickness of bottom of the thermowell can be neglected for dimensioning. It is offset by the spring travel of the measuring insert.

Available documentation, certificates

- 2.2 Test certificate
- 3.1 Acceptance test certificate
- DKD certificate
- Hygiene certificates

Certificate	Clamp	VARIVENT®	BioControl®	DIN 11851
3-A (74-03)	yes	yes	yes	yes ⁹⁾
EHEDG	yes ¹⁰⁾	yes	no	yes ⁹⁾

- 9) In combination with
 - ASEPTO-STAR k-flex upgrade gaskets from Kieselmann GmbH, Germany or
 - SKS gasket set DIN 11851 EHEDG from Siersema Komponenten
- 10) In combination with
 - Kalrez/Stainless steel gasket from Dupont de Nemours, Switzerland or
 - T-ring seals from Combifit International B. V., Netherlands

Overview of the combination options

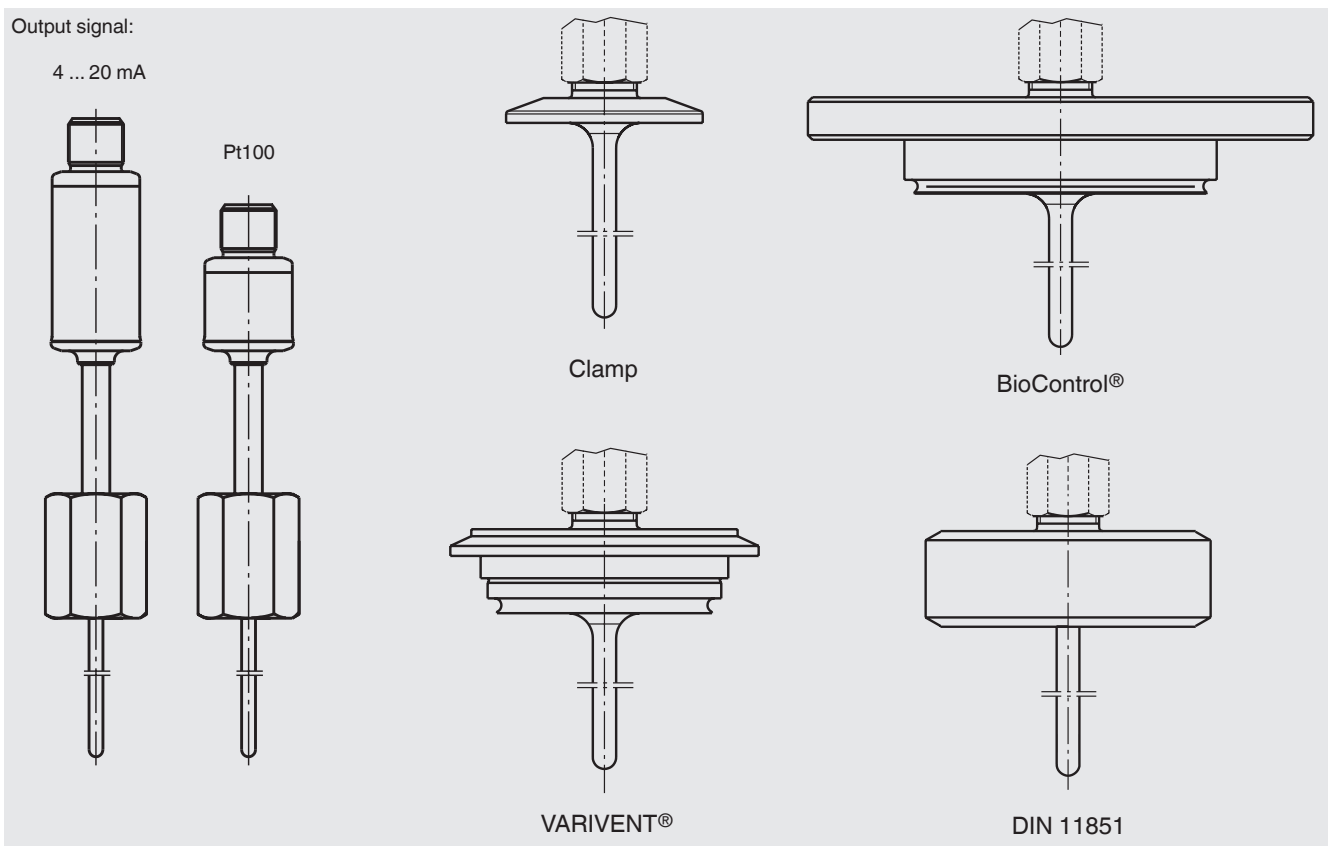

VARIVENT® is a registered trademark of the company Tuchenhausen.
 BioControl® is a registered trademark of the company NEUMO.

Dimensions in mm

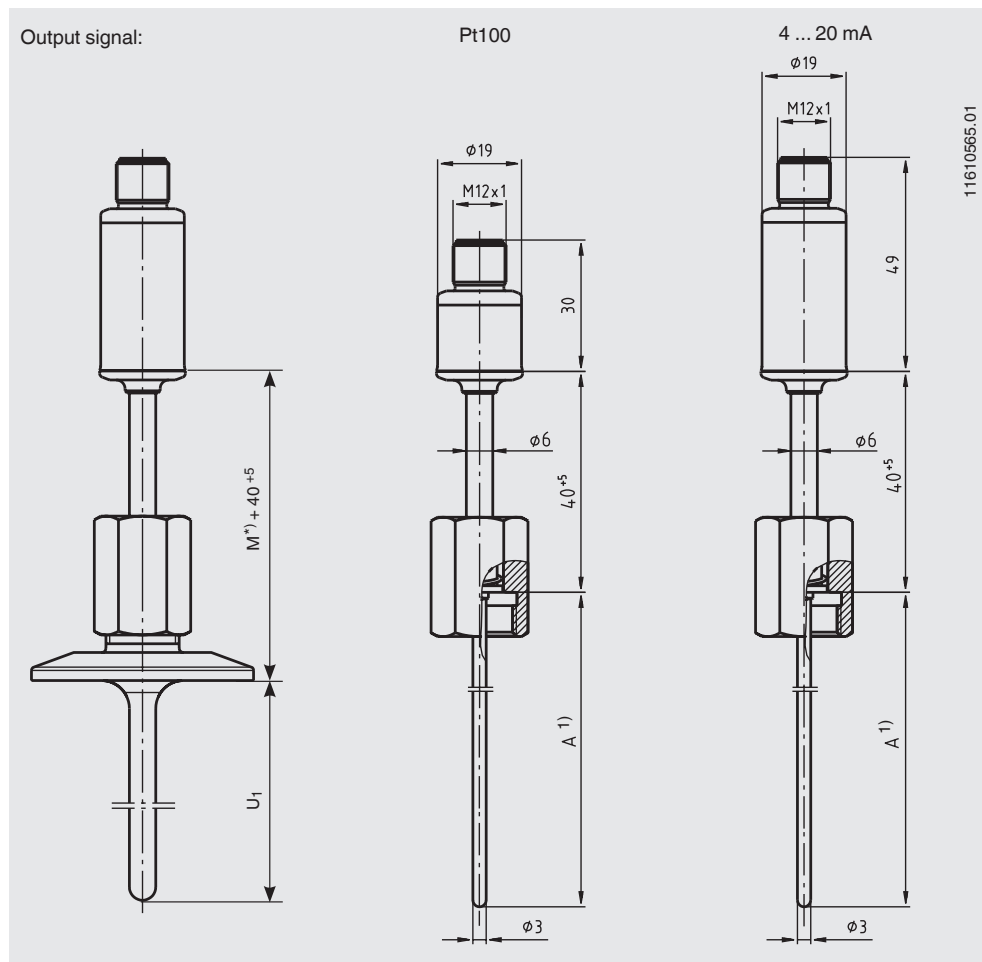

*) see table of dimensions
 1) In the event of replacement,
 calculate sensor length, A, as
 follows: $A_{TR21-A} = U_1 + M$

Dimensions of the process connections in mm (model TW22 thermowells)

Clamp process connection

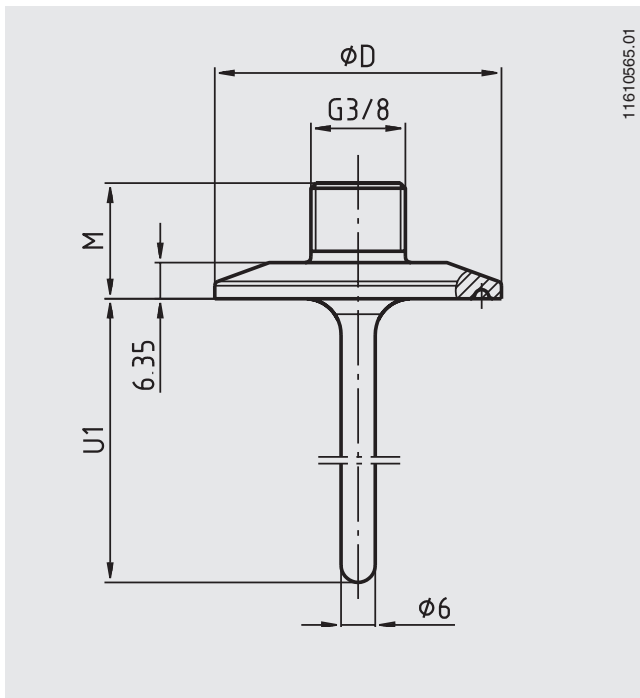

U_1 = variable insertion length

VARIVENT® process connection

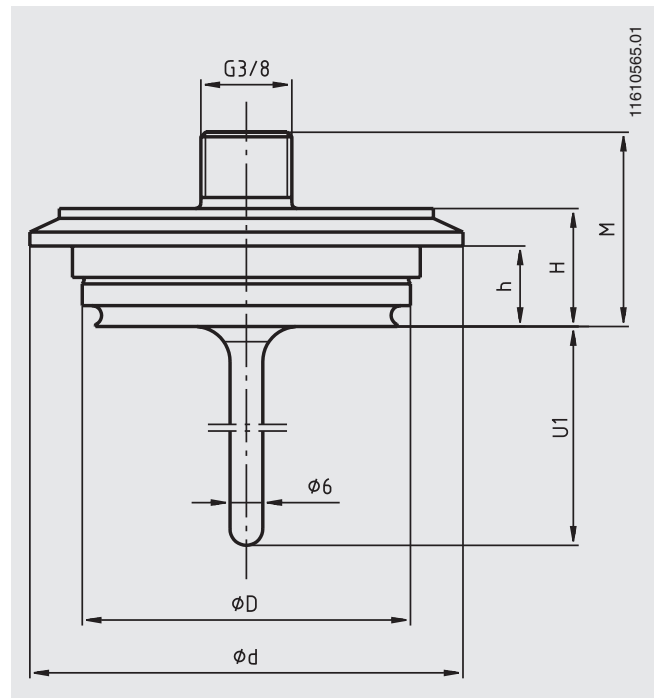

U_1 = variable insertion length

Dimensions for clamp process connection

Process connection	Nominal width in mm/inch	PN in bar	Dimensions in mm		Weight in kg
			ϕD	M	
DIN 32676 for pipes to DIN 11866 series A	DN 10 ... 20	16	34.0	20.35	0.2
	DN 25 ... 40	16	50.5	20.35	0.3
	DN 50	16	64.0	20.35	0.4
DIN 32676 for pipes to DIN 11866 series B	13.5 ... 17.2	16	25.0	20.35	0.2
	21.3 ... 33.7	16	50.5	20.35	0.3
	42.4 ... 48.3	16	64.0	20.35	0.3
DIN 32676 for pipes to DIN 11866 series C	1/2" ... 3/4"	16	25.0	20.35	0.2
	1" ... 1 1/2"	16	50.5	20.35	0.3
	2"	16	64.0	20.35	0.4
Tri-clamp	1/2"	16	25.0	20.35	0.2
	3/4"	16	25.0	20.35	0.2
	1"	16	50.5	20.35	0.3
	1 1/2"	16	50.5	20.35	0.3
	2"	16	64.0	20.35	0.4
ISO 2852	DN 12 ... 21.3	16	34.0	20.35	0.2
	DN 25 ... 38	16	50.5	20.35	0.3
	DN 40 ... 51	16	64.0	20.35	0.4

Dimensions for VARIVENT process connection

Process connection	Nominal width in mm	PN in bar	Dimensions in mm					Weight in kg
			ϕD	M	ϕd	H	h	
Form B	DN 10, DN 15	25	31	34	52.7	20	13.65	0.3
Form F	DN 25, DN 32	25	50	32	66.0	18	12.30	0.4
Form N	DN 40, DN 50	16	68	32	84.0	18	12.30	0.6

NEUMO BioControl® process connection

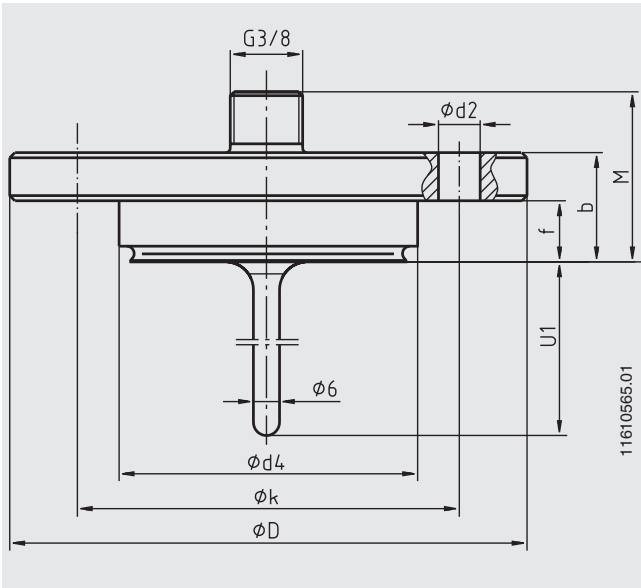

U_1 = variable insertion length

Union nut process connection DIN 11851 with conical coupling (milk thread fitting)

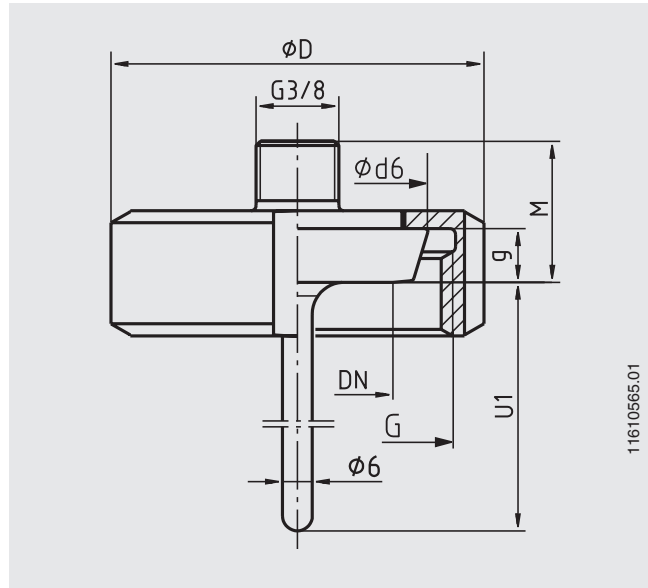

U_1 = variable insertion length

For a detailed description of the BioControl® housings, see data sheet AC 09.14.

Dimensions for NEUMO BioControl® process connection

Case size	Nominal width in mm	PN in bar	Dimensions in mm							
			U_1 ¹⁾	$\phi d4$	ϕD	M	f	b	ϕk	$\phi d2$
Size 25	DN 8	16	5	30.5	64	34	11	20	50	4 x $\phi 7$
	DN 10	16	6	30.5	64	34	11	20	50	4 x $\phi 7$
	DN 15	16	9	30.5	64	34	11	20	50	4 x $\phi 7$
	DN 20	16	11	30.5	64	34	11	20	50	4 x $\phi 7$
Size 50	DN 25	16	15	50.0	90	41	17	27	70	4 x $\phi 9$
	DN 40	16	20	50.0	90	41	17	27	70	4 x $\phi 9$
	DN 50	16	25	50.0	90	41	17	27	70	4 x $\phi 9$
	DN 65	16	35	50.0	90	41	17	27	70	4 x $\phi 9$
	DN 80	16	45	50.0	90	41	17	27	70	4 x $\phi 9$
Size 65	DN 100	16	55	50.0	90	41	17	27	70	4 x $\phi 9$
	DN 40	16	20	68.0	120	41	17	27	95	4 x $\phi 11$
	DN 50	16	25	68.0	120	41	17	27	95	4 x $\phi 11$
	DN 65	16	35	68.0	120	41	17	27	95	4 x $\phi 11$
	DN 80	16	45	68.0	120	41	17	27	95	4 x $\phi 11$
DN 100	16	55	68.0	120	41	17	27	95	4 x $\phi 11$	

1) Recommended insertion length for installation in BioControl® flow-through housing; other insertion lengths are possible

Dimensions for union nut process connection DIN 11851 with conical coupling (milk thread fitting)

Nominal width in mm	PN in bar	Dimensions in mm					Weight in kg
		$\phi d6$	G	ϕD	M	g	
DN 20	40	36.5	RD 44 x $1/6$	54	26	8	0.4
DN 25	40	44.0	RD 52 x $1/6$	63	26	10	0.5
DN 32	40	50.0	RD 58 x $1/6$	70	26	10	0.6
DN 40	40	56.0	RD 65 x $1/6$	78	26	10	0.8
DN 50	25	68.5	RD 78 x $1/6$	92	26	11	0.9

Other process connections and nominal widths available on request.

Accessories

Configuration set

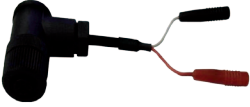
Model	Special features	Order no.
Programming unit Model PU-448 	<ul style="list-style-type: none"> ■ Easy to use ■ LED status display ■ Compact design ■ No further power supply is needed for either the programming unit or for the transmitter ■ Measuring the loop current of the model T24 transmitter and the model TR21, TR30 and TR31 resistance thermometers is possible 	11606304
Adapter cable M12 to PU-448 	Adapter cable for the connection of a model TR21-A resistance thermometer to the PU-448 programming unit	14003193

Software

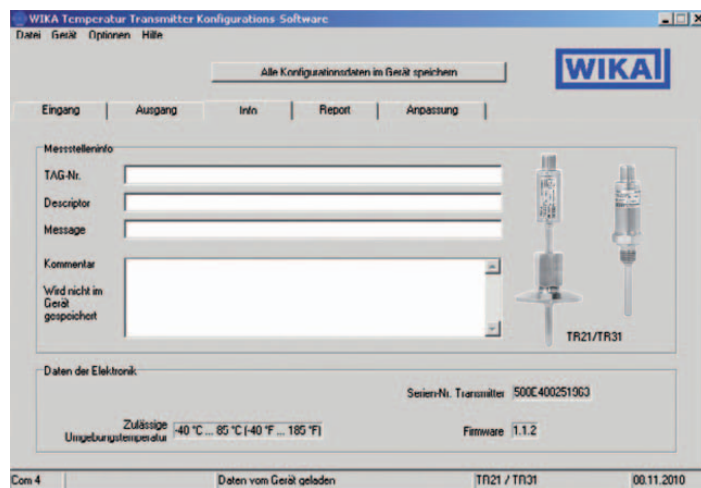

WIKI_TT configuration software (multilingual) as a free download from www.wika.com

Connecting PU-448 programming unit

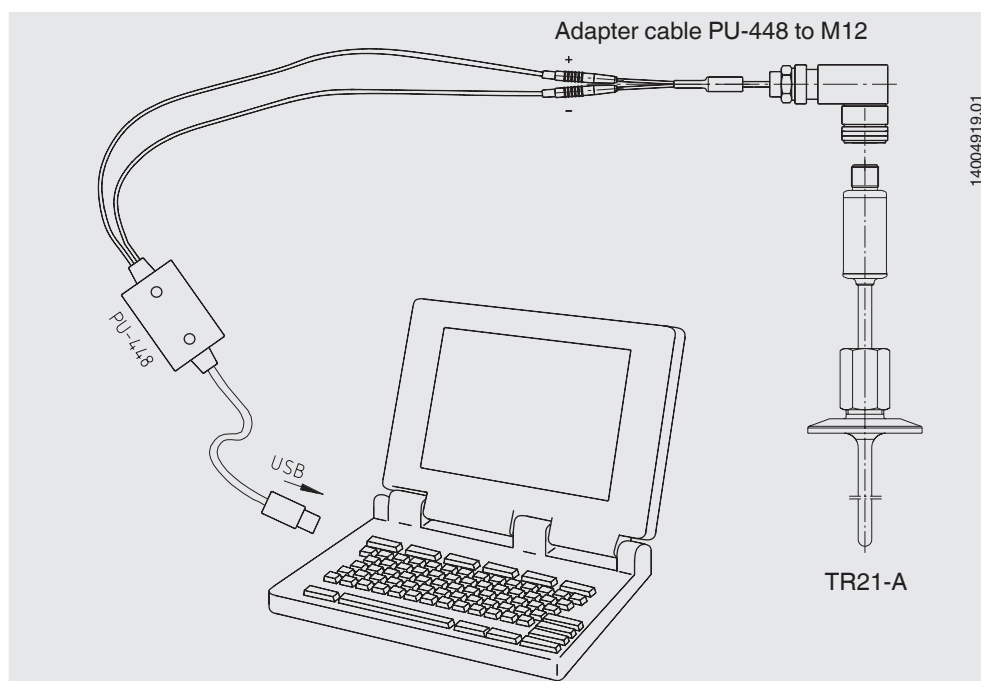

Electrical connection

Pt100 (circular connector M12 x 1, 4-pin)

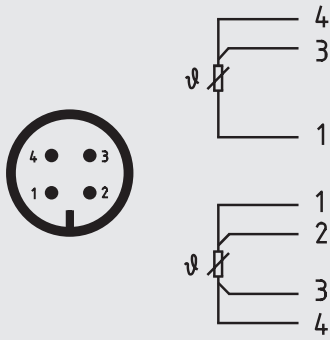

Transmitter (circular connector M12 x 1, 4-pin)

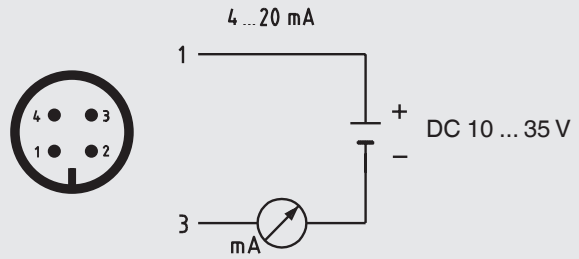

Load diagram

The permissible load depends on the loop supply voltage.

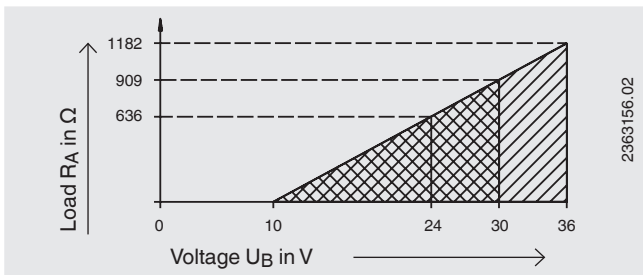

Ordering information

Model / Output / Sensor / Transmitter / Thermowell / Process connection / Thermowell diameter / Wetted-parts materials / Insertion length / Certificates / Options

© 2010 WIKA Alexander Wiegand SE & Co. KG, all rights reserved.
The specifications given in this document represent the state of engineering at the time of publishing.
We reserve the right to make modifications to the specifications and materials.

