

Resistance thermometer For sanitary applications Model TR22-A, with flange connection

WIKA data sheet TE 60.22



Applications

- Sanitary applications
- Food industry
- Beverage industry
- Bio and pharmaceutical industry, production of active ingredients
- Paint finishing systems

Special features

- Simplified calibration through removable measuring inserts
- Materials and surface finish quality in accordance with the standards of hygienic designs
- Stainless steel connection head in optimised hygienic design
- Pt100, 4 ... 20 mA or HART protocol, FOUNDATION™ fieldbus and PROFIBUS® PA output possible



**Resistance thermometer model TR22-A,
VARIVENT® connection**
Options: Sealing combination at neck tube, cable gland in hygienic design

Description

The model TR22-A resistance thermometer is used for temperature measurement in sanitary applications. The process connections meet the stringent requirements, in terms of materials and design, of hygienic measuring points. For increased hygiene requirements for those elements in contact with the surrounding environment, a stainless steel head is available in an optimised Hygienic Design.

Due to the rotatable screw connection to the connection head, it is possible to loosen the connection head and to adjust it in the desired position. The connection head can be removed together with the measuring insert. This allows the resistance thermometer to be calibrated along with the whole measuring chain, i.e. without disconnecting the electrical connections. In addition this avoids having to open the process, and thus the risk of contamination is minimised.

The spring-loaded measuring insert guarantees the contact between the sensor tip and the bottom of the thermowell and thus ensures a fast response time and high accuracy.

The welded junction between the thermowell and the flange makes the use of a sealing as additional material in those areas redundant which are in contact with the product.

Specifications

Output signal Pt100

Temperature range	Measuring range -50 ... +250 °C
Measuring element	Pt100 (measuring current: 0.1 ... 1.0 mA) standard measuring resistor Pt100 (measuring current: 0.1 ... 1.0 mA) face-sensitive measuring resistor ¹⁾
Connection method	1 x 3-wire 1 x 4-wire 2 x 3-wire
Sensor tolerance value ²⁾ per DIN EN 60751	Class AA Class A Class B
Response time ³⁾	t ₅₀ < 4.7 s t ₉₀ < 12.15 s
Measuring insert diameter	3 mm

Output signal 4 ... 20 mA, HART[®] protocol, FOUNDATION[™] fieldbus and PROFIBUS[®] PA

Transmitter (selectable versions) ⁴⁾	model T19	model T24	model T32	model T53
Output				
■ 4 ... 20 mA	x	x	x	
■ HART [®] protocol			x	
■ FOUNDATION [™] Fieldbus and PROFIBUS [®] PA				x
Connection method				
■ 1 x 3-wire	x	x	x	x
■ 1 x 4-wire			x	x
Measurement current	0.8 mA	0.5 mA	0.3 mA	0.2 mA
Temperature range	Measuring range -50 ... +250 °C ⁵⁾ , other measuring ranges are adjustable			
Response time ³⁾	t ₅₀ < 4.7 s or t ₉₀ < 12.15 s + response time of the relevant transmitters (see data sheet of the relevant transmitter)			
Measuring insert diameter	3 mm			

Thermowell model TW22

Surface finish	Standard: R _a < 0.8 μm Optional: R _a < 0.8 μm electropolished, R _a < 0.4 μm, R _a < 0.4 μm electropolished
Materials	Stainless steel 1.4435 (316L)
Connection to the thermometer	M24 x 1.5
Thermowell diameter	6 mm, optional: probe tip reduced to 4.5 mm (from U ₁ > 25 mm)
Insertion length U ₁ ⁶⁾	Standard: 25, 50, 75, 100, 150, 200 mm other insertion lengths are available as options
Neck tube length M	85 mm, others on request
Neck tube diameter	up to DN 20: 9 mm (except per DIN 11851 (milk thread fitting): 12 mm) from DN 25: 12 mm
Process connections	<ul style="list-style-type: none"> ■ Clamp ■ VARIVENT[®] ■ BioControl[®] ■ Union nut DIN 11851 other process connections on request

1) Face-sensitive measuring resistors, through their small design they serve to reduce the heat dissipation with short insertion lengths.

Available for the temperature range -50 ... +150 °C in classes A and B.

For thermowell insertion lengths of less than 11 mm, face-sensitive measuring resistors are generally used.

2) For detailed specifications for Pt100 sensors, see Technical Information IN 00.17 at www.wika.com.

3) Measurement in accordance with DIN EN 60751

4) For a correct determination of the overall measuring error, both sensor and transmitter measuring deviations have to be considered.

5) The temperature transmitter should therefore be protected from temperatures over 85 °C

6) For the TR22-A design without thermowell, the insertion length is defined by the dimension A(l₁) from the lower edge of the connection head to the tip of the measuring insert (see "Dimensions of the connection head in mm"). The thickness of bottom of the thermowell can be neglected for dimensioning. It is offset by the spring travel of the measuring insert.

Available documentation, certificates

- 2.2 Test certificate
- 3.1 Acceptance test certificate
- DKD certificate
- Hygiene certificates

Certificate	Clamp	VARIVENT [®]	BioControl [®]	DIN 11851
3-A (74-03)	yes	yes	yes	yes ⁷⁾
EHEDG	yes ⁸⁾	yes	no	yes ⁷⁾

7) In combination with

- ASEPTO-STAR k-flex upgrade gaskets from Kieselmann GmbH, Germany or
- SKS gasket set DIN 11851 EHEDG from Siersema Komponenten

8) In combination with

- Kalrez/Stainless steel gasket from Dupont de Nemours, Switzerland or
- T-ring seals from Combifit International B. V., Netherlands

Options

The transition from the connection head to the thermowell is effected via an optional sealing combination of flat gasket and wiper. This combination permanently prevents the penetration and depositing of humidity and impurities in this area (IP 68). Additionally, the sealing combination simplifies the cleaning process significantly.

The design of the BVS head combined with the cable gland in hygienic design results in an easy to clean and hygienic measuring location, even in areas which are not in contact with the product.

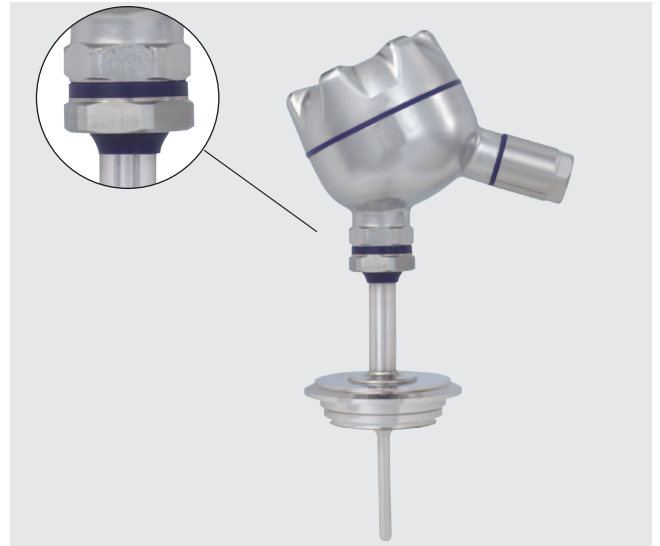

Connection head

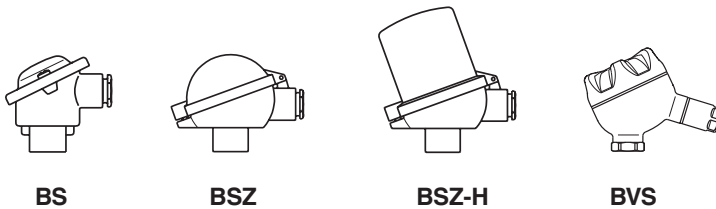

Model	Material	Cable entry	Ingress protection	Cap	Surface finish	Weight in kg
BS	Aluminium	M20 x 1.5 ¹⁾	IP 65	Cap with 2 screws	blue, lacquered ²⁾	0.142
BSZ	Aluminium	M20 x 1.5 ¹⁾	IP 65	Hinged cover with cylinder head screw	blue, lacquered ²⁾	0.29
BSZ-H	Aluminium	M20 x 1.5 ¹⁾	IP 65	Hinged cover with cylinder head screw	blue, lacquered ²⁾	0.303
BVS	Stainless steel	M20 x 1.5 ¹⁾	IP 68	Screw cover	precision casting, electropolished	0.50

1) Standard

2) RAL5022, polyester paint saltwater-resistant

Connection head with digital indicator (option)

As an alternative to the standard connection head the thermometer can be fitted with an optional DIH10 digital indicator. The connection head used for this is similar to the model BSZ-H head. For operation, a 4 ... 20 mA transmitter is needed, which is mounted to the measuring insert. The indication range is configured identically to the measuring range of the transmitter.



Fig. connection head with digital indicator, model DIH10

Transmitter (option)

Depending on the connection head used, a transmitter can be mounted within the thermometer.

- Mounted instead of terminal block
- Mounted within the cap of the connection head
- Mounting not possible

Connection head	Transmitter model			
	T19	T24	T32	T53
BS	○	○	-	○
BSZ	○	○	○	○
BSZ-H	●	●	●	●
BVS	○	○	○	○

Mounting of 2 transmitters on request.

Model	Description	Explosion protection	Data sheet
T19	Analogue transmitter, configurable	without	TE 19.03
T24	Analogue transmitter, PC configurable	optional	TE 24.01
T32	Digital transmitter, HART® protocol	optional	TE 32.04
T53	Digital transmitter FOUNDATION™ Fieldbus and PROFIBUS® PA	standard	TE 53.01

Overview of the process connections, thermowell variants

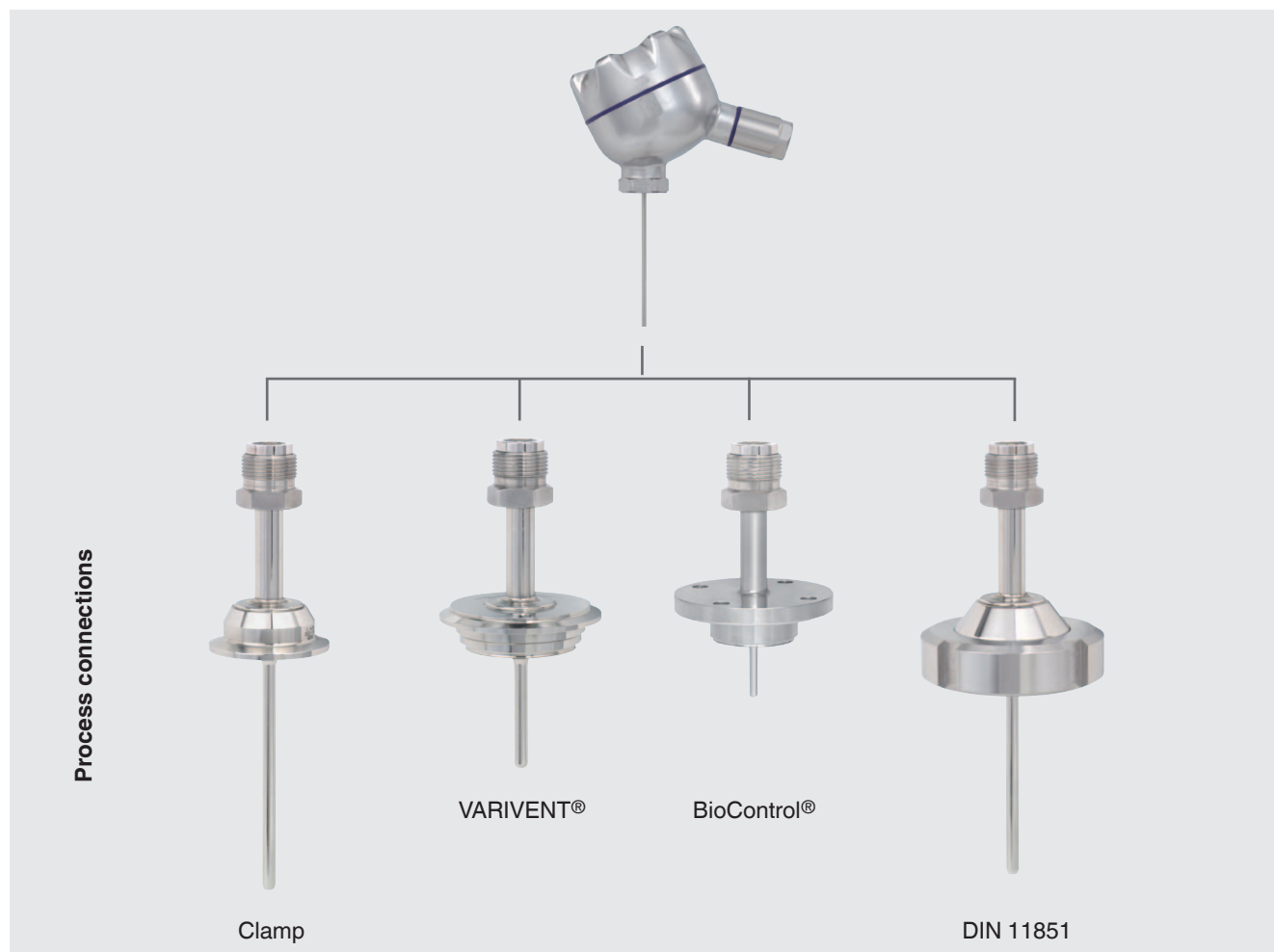

VARIVENT® is a registered trademark of the company Tuchenhagen
 BioControl® is a registered trademark of the company NEUMO.

Dimensions in mm

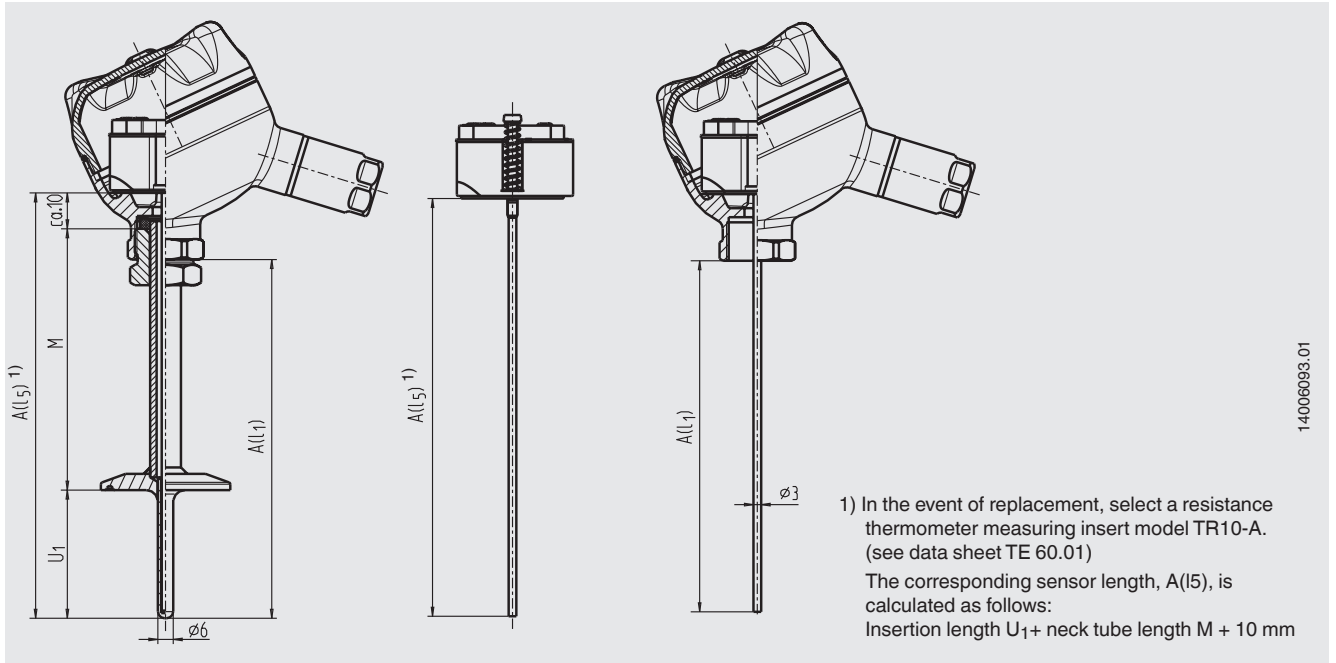

Dimensions of the connection heads in mm

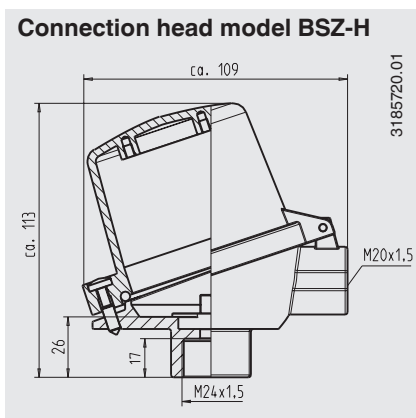
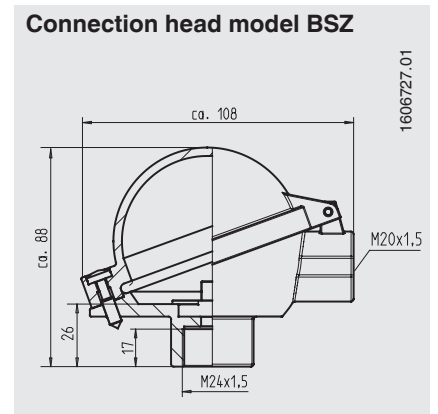
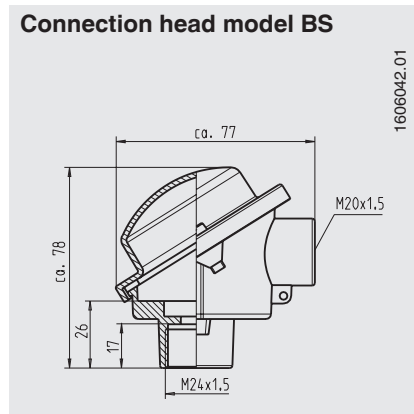
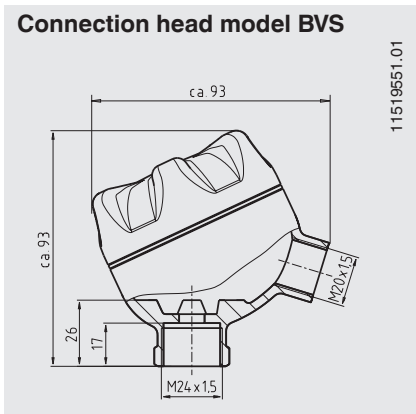

Dimensions of the process connections in mm (model TW22 thermowells)

Clamp process connection

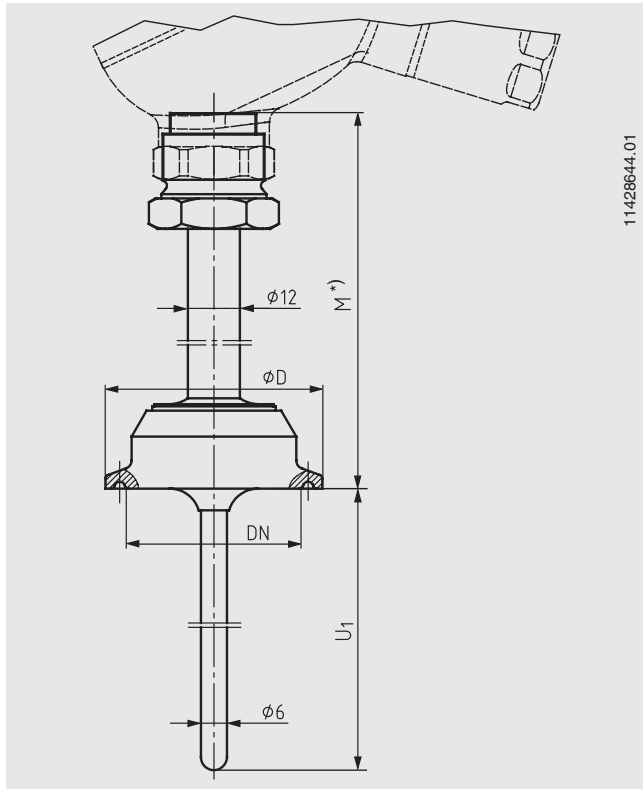

*) M = 85 mm, others on request
U₁ = variable insertion length

VARIVENT® process connection

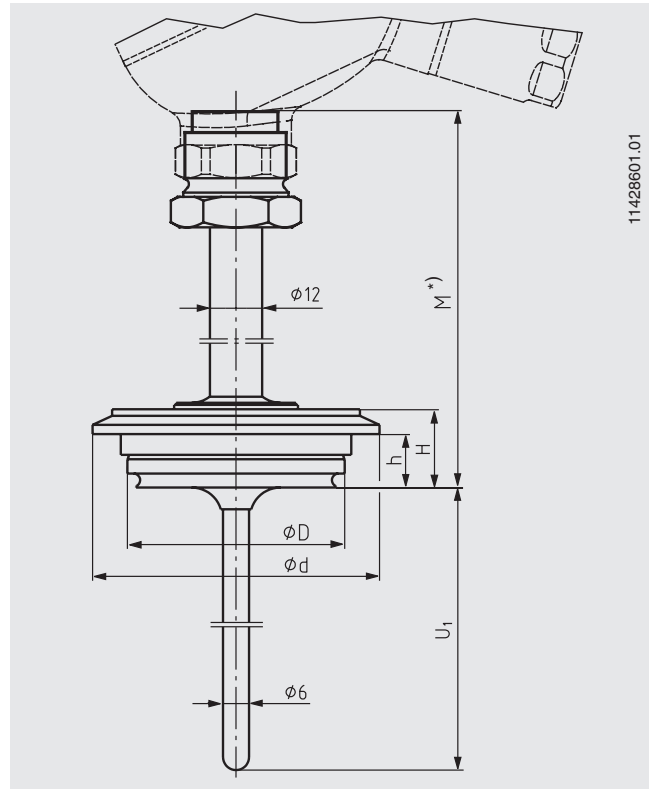

*) M = 85 mm, others on request
U₁ = variable insertion length

Dimensions for clamp process connection

Process connection	Nominal width in mm/inch	PN in bar	Dimensions in mm Ø D	Weight in kg
DIN 32676 for pipes to DIN 11866 series A	DN 10 ... 20	16	34.0	0.2
	DN 25 ... 40	16	50.5	0.3
	DN 50	16	64.0	0.4
DIN 32676 for pipes to DIN 11866 series B	13.5 ... 17.2	16	25.0	0.2
	21.3 ... 33.7	16	50.5	0.3
	42.4 ... 48.3	16	64.0	0.3
DIN 32676 for pipes to DIN 11866 series C	1/2" ... 3/4"	16	25.0	0.2
	1" ... 1 1/2"	16	50.5	0.3
	2"	16	64.0	0.4
Tri-clamp	1/2"	16	25.0	0.2
	3/4"	16	25.0	0.2
	1"	16	50.5	0.3
	1 1/2"	16	50.5	0.3
ISO 2852	2"	16	64.0	0.4
	DN 12 ... 21.3	16	34.0	0.2
	DN 25 ... 38	16	50.5	0.3
	DN 40 ... 51	16	64.0	0.4

Dimensions for VARIVENT® process connection

Process connection	Nominal width in mm	PN in bar	Dimensions in mm			Weight in kg	
			Ø D	Ø d	H	h	
Form B	DN 10, DN 15	25	31	52.7	20	13.65	0.3
Form F	DN 25, DN 32	25	50	66	18	12.3	0.4
Form N	DN 40, DN 50	25	68	84	18	12.3	0.6

NEUMO BioControl® process connection

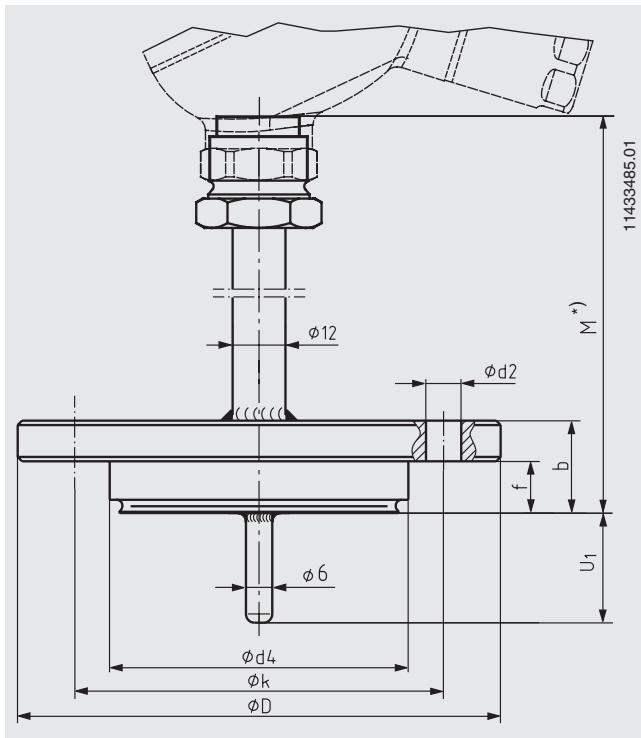

*) M = 85 mm, others on request

The housings are not part of the scope of delivery of the resistance thermometers and can be ordered as an separate position.

For a detailed description of the BioControl® housings, see data sheet AC 09.14

Union nut process connection, DIN 11851 with conical coupling (milk thread fitting)

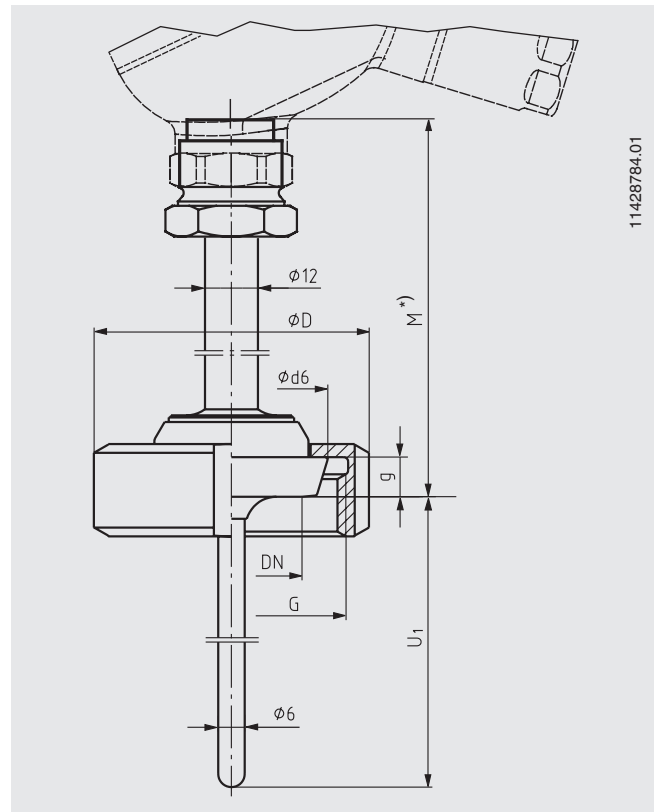

*) M = 85 mm, others on request
U₁ = variable insertion length

Dimensions for NEUMO BioControl® process connection

Case size	Nominal width of tube	PN in bar	Dimensions in mm						
			U ₁ ¹⁾	Ø d ₄	Ø D	f	b	Ø k	Ø d ₂
Size 25	DN 8	16	5	30.5	64	11	20	50	4 x Ø 7
	DN 10	16	6	30.5	64	11	20	50	4 x Ø 7
	DN 15	16	9	30.5	64	11	20	50	4 x Ø 7
	DN 20	16	11	30.5	64	11	20	50	4 x Ø 7
Size 50	DN 25	16	15	50.0	90	17	27	70	4 x Ø 9
	DN 40	16	20	50.0	90	17	27	70	4 x Ø 9
	DN 50	16	25	50.0	90	17	27	70	4 x Ø 9
	DN 65	16	35	50.0	90	17	27	70	4 x Ø 9
	DN 80	16	45	50.0	90	17	27	70	4 x Ø 9
Size 65	DN 100	16	55	50.0	90	17	27	70	4 x Ø 9
	DN 40	16	20	68.0	120	17	27	95	4 x Ø 11
	DN 50	16	25	68.0	120	17	27	95	4 x Ø 11
	DN 65	16	35	68.0	120	17	27	95	4 x Ø 11
	DN 80	16	45	68.0	120	17	27	95	4 x Ø 11
	DN 100	16	55	68.0	120	17	27	95	4 x Ø 11

1) Recommended insertion length for installation in BioControl® flow-through housing; other insertion length are possible

Dimensions for union nut process connection, DIN 11851 with conical coupling (milk thread fitting)

Nominal width in mm	PN in bar	Dimensions in mm				Weight in kg
		Ø d ₆	G	Ø D	g	
DN 20	40	36.5	RD 44 x 1/6	54	8	0.4
DN 25	40	44	RD 52 x 1/6	63	10	0.5
DN 32	40	50	RD 58 x 1/6	70	10	0.6
DN 40	40	56	RD 65 x 1/6	78	10	0.8
DN 50	25	68.5	RD 78 x 1/6	92	11	0.9

Explosion protection (option)

Resistance thermometers of the TR22-A series are available with a EC type-examination certificate for "intrinsically safe", Ex-i, ignition protection.

These instruments comply with the requirements of 94/9/EC (ATEX) directive for gas and dust. Manufacturer's declarations in accordance with NAMUR NE24 are also available.

The classification/suitability of the instrument (permissible power P_{max} as well as the permissible ambient temperature) for the respective category can be seen on the EC type-examination certificate and in the operating instructions.

Built-in transmitters have their own EC type-examination certificate. The permissible ambient temperature ranges of the built-in transmitters can be taken from the corresponding transmitter approval. The system operator is responsible for using suitable thermowells.

Electrical connection

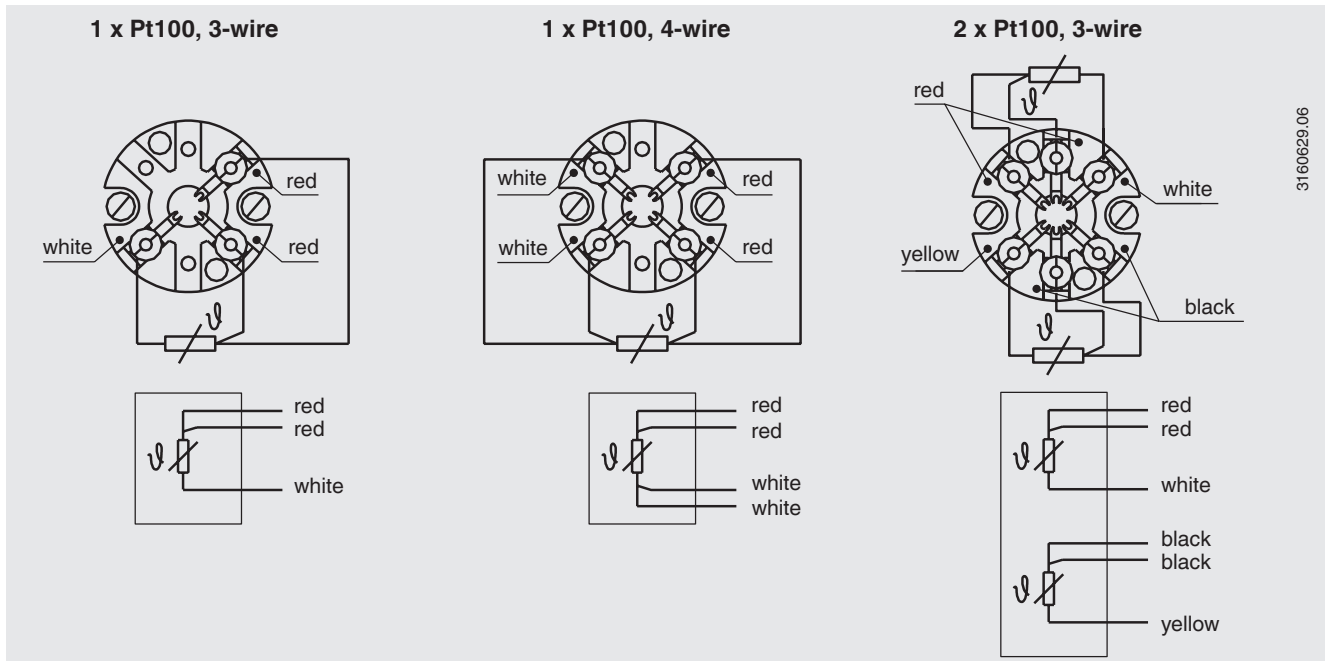

For the electrical connections of built-in temperature transmitters see the corresponding transmitter data sheets or operating instructions.

Ordering information

Model / Explosion protection / Sensor / Accuracy class / Connection head / Cable gland / Transmitter / Thermowell / Process connection / Thermowell diameter / Wetted-parts materials / Neck-tube length / Certificates / Optional further seal combinations

© 2011 WIKA Alexander Wiegand SE & Co. KG, all rights reserved.
The specifications given in this document represent the state of engineering at the time of publishing.
We reserve the right to make modifications to the specifications and materials.

